

CUTTING DATA RECOMMENDATIONS

Uddeholm Vanadis 60

Machining data are always dependent on the actual operation, the machine tool and the cutting data used. The machining data given in this datasheet are general guidelines that may have to be adjusted to the actual conditions of a specific machining operation.



Cutting data formulae

Turning

$$\text{Cutting speed, } v_c = \frac{\pi \cdot D \cdot n}{1000} \quad (\text{m/min})$$

$$\text{Spindle speed, } n = \frac{1000 \cdot v_c}{\pi \cdot D} \quad (\text{rev/min})$$

$$\text{Material removal rate, } Q = v_c \cdot a_p \cdot f \quad (\text{cm}^3/\text{min})$$

$$\text{Surface roughness, } R_a \approx \frac{f^2 \cdot 50}{r_\varepsilon} \quad (\mu\text{m})$$

Legend

- v_c = Cutting speed (m/min)
- n = Spindle speed (rev/min)
- f = Feed per rev (mm/rev)
- a_p = Axial depth of cut (mm)
- D = Workpiece diameter (mm)
- Q = Material removal rate (cm³/min)
- R_a = Surface roughness (μm)
- r_ε = Nose radius (mm)

Milling

$$v_c = \frac{\pi \cdot D \cdot n}{1000} \quad (\text{m/min})$$

$$n = \frac{1000 \cdot v_c}{\pi \cdot D} \quad (\text{rev/min})$$

$$v_f = f_z \cdot z \cdot n = f \cdot n \quad (\text{mm/min})$$

$$h_m = f_z \cdot \sqrt{\frac{a_e}{D}} \quad (\text{mm}) \quad \frac{a_e}{D} < 0,3$$

$$Q = \frac{a_p \cdot a_e \cdot v_f}{1000} \quad (\text{cm}^3/\text{min})$$

Legend

- v_c = Cutting speed (m/min)
- n = Spindle speed (rev/min)
- v_f = Feed speed (mm/min)
- a_p = Axial depth of cut (mm)
- a_e = Radial depth of cut (mm)
- f = Feed per rev (mm/rev)
- z = Number of teeth
- f_z = Feed per tooth (mm/tooth)
- D = Cutter diameter (mm)
- h_m = Average chip thickness (mm)
- Q = Material removal rate (cm³/min)



Drilling

$$\text{Cutting speed, } v_c = \frac{\pi \cdot D \cdot n}{1000} \quad (\text{m/min})$$

$$\text{Spindle speed, } n = \frac{1000 \cdot v_c}{\pi \cdot D} \quad (\text{rev/min})$$

$$\text{Feed speed, } v_f = f \cdot n \quad (\text{mm/min})$$

$$\text{Feed per rev, } f = \frac{v_f}{n} \quad (\text{mm/rev})$$

Legend

- v_c = Cutting speed (m/min)
- n = Spindle speed (rev/min)
- v_f = Feed speed (mm/min)
- D = Drill diameter (mm)
- f = Feed per rev (mm/rev)

Turning

Uddeholm Vanadis 60

Turning 	Cemented carbide		HSS
	Roughing	Finishing	
Cutting speed, v_c (m/min)	60-90	90-110	6-10
Feed, f (mm/rev)	0,2-0,4	0,05-0,2	0,05-0,3
Depth of cut, a_p (mm)	2-4	0,5-2	0,5-3
Suitable grades	K20, P20 coated carbide	K15, P15 coated carbide	

Remarks:

1. Cutting fluid is recommended.
2. For turning with interrupted cut or face turning of large workpieces use a tougher cemented carbide grade.

Face milling

Face milling 	Cemented carbide	
	Roughing	Finishing
Cutting speed, v_c (m/min)	40-60	60-80
Feed, f_z (mm/tooth)	0,2-0,4	0,1-0,2
Depth of cut, a_p (mm)	2-4	-2
Suitable grades	K20, P20 coated carbide	K15, P15 coated carbide

Remarks:

1. Use a milling cutter with a positive-negative or positive-positive geometry.
2. Climb milling should generally be used.
3. Milling should generally be done without coolant.
If a high surface finish is required coolant may be used.
4. Cermet can be of use when finishing under stable conditions.

Square shoulder milling

Square shoulder milling with cemented carbide 	$a_e = 0.1 \times D$	$a_e = 0.5 \times D$	$a_e = 1 \times D$
	Cutting speed, v_c (m/min)	80-90	50-70
Feed, f_z (mm/tooth)	0,25-0,3	0,15-0,2	0,1-0,15
Suitable grades	K20, P20 coated carbide		

Remarks:

1. Climb milling should generally be used.
2. Choose the cutter diameter (D) and the radial depth of cut (a_e) so that at least two cutting edges are engaged simultaneously.
3. If the machine tool power is inadequate for the data given reduce the depth of cut, but do not reduce the feed.

Slot milling Axial depth of cut, $a_p = 1 \times D$		Cutter diameter (mm)				
		3 - 5	5 - 10	10 - 20	20 - 30	30 - 40
Coated HSS ¹⁻⁴⁾	Cutting speed, v_c (m/min)	10-14				
	Feed, f_z (mm/tooth)	0,015-0,03	0,03-0,04	0,04-0,05	0,05-0,06	0,06-0,09
Solid cemented carbide ⁵⁻⁸⁾	Cutting speed, v_c (m/min)	30-40				
	Feed, f_z (mm/tooth)	0,006-0,01	0,01-0,02	0,02-0,04		
Indexable insert ⁶⁻⁸⁾ (cemented carbide inserts)	Cutting speed, v_c (m/min)	40-60				
	Feed, f_z (mm/tooth)			0,06-0,08	0,08-0,10	0,10-0,12
	Suitable grades	K15, P20 coated carbide				
Side milling Axial depth of cut, $a_p = 1.5 \times D$		For side milling the same cutting speed as for slot milling can be used, but the feeds must be adjusted in order to obtain a suitable average chip thickness.				

Correction factor for side milling

Divide the cutter diameter with the radial depth of cut. See in the chart below which correction factor, C_f , this corresponds to, and multiply the chosen feed in the table for slot milling with this factor.

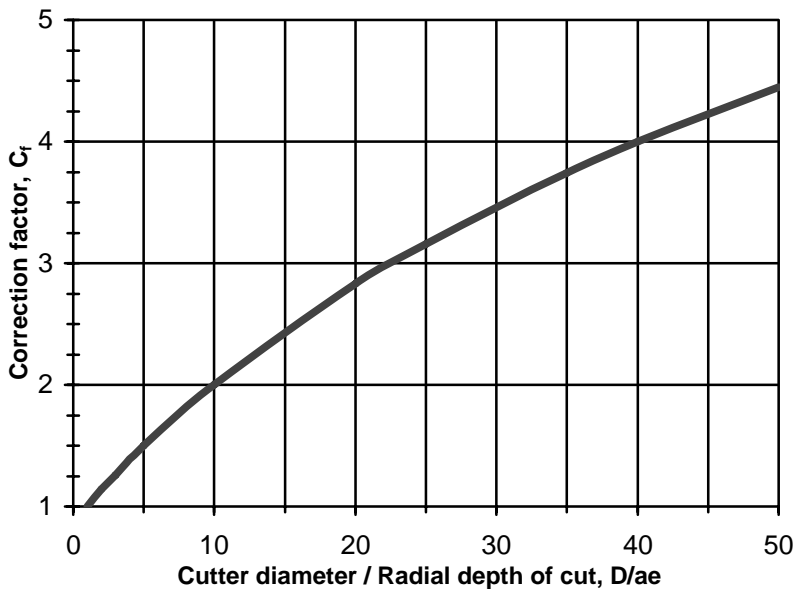

Example:

Tool:
CC insert

Cutter diameter:
 $D = 40$ mm

Radial depth of cut
 $a_e = 2$ mm

$$D/a_e = 40/2 = 20$$

Feed acc. to table slot milling = 0.11 mm/tooth
Correction factor acc. to chart: $C_f = 2.8$

Feed for side milling:
 $f_z = 2.8 \times 0.11 = 0.31$ mm/tooth

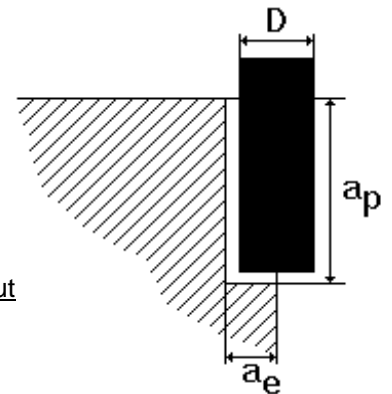

Remarks: (slot and side milling)

1. Climb milling is generally recommended.
2. Use a cutter with chipbreaker when side milling with radial depths of cut, $a_e > 0.3 \times D$.
3. When side milling with small radial depths of cut (a_e) the cutting speed can be increased by up to 15%.
4. Use liberal amounts of cutting fluid.
5. It is recommended to use a TiCN coated cutter when milling with solid cemented carbide tools.
The axial depth of cut should not exceed the cutter diameter when slot milling.
6. Climb milling is generally recommended.
7. When side milling with small radial depths of cut (a_e) the cutting speed can be increased by up to 30%.
8. The radial run-out, at the cutting edges, must be small and not exceed 0.03 mm.

Drilling		Drill diameter (mm)				
		1 - 5	5 - 10	10 - 20	20 - 30	30 - 40
Uncoated HSS ¹⁻²⁾	Cutting speed, v_c (m/min)	6-8				
	Feed, f (mm/rev)	0,05-0,10	0,10-0,20	0,20-0,30	0,30-0,35	0,35-0,40
Coated HSS ¹⁻²⁾	Cutting speed, v_c (m/min)	12-14				
	Feed, f (mm/rev)	0,07-0,18	0,18-0,25	0,25-0,35	0,35-0,40	0,40-0,45
Indexable insert ³⁻⁴⁾ (cem. carbide inserts)	Cutting speed, v_c (m/min)				80-100	
	Feed, f (mm/rev)				0,05-0,10	0,10-0,15
Solid cemented carbide ⁵⁻⁷⁾	Cutting speed, v_c (m/min)	40-60				
	Feed, f (mm/rev)		0,08-0,10	0,10-0,20	0,20-0,30	0,30-0,35
Brazed cemented carbide ⁵⁻⁷⁾	Cutting speed, v_c (m/min)	20-30				
	Feed, f (mm/rev)				0,15-0,25	0,25-0,35
					0,35-0,40	

Remarks:

1. The cutting fluid should be ample and directed at the tool.
2. When drilling with short "NC drills" the feed may be increased by up to 20%.
For extra long drills the feed must be decreased.
3. TiCN-coating is recommended when drilling with coated HSS.
4. Use insert grades in the range of ISO P20-P30.
Under unstable conditions a tougher carbide grade should be used for the centre position.
5. Use a high cutting fluid pressure and flow rate for a good chip removal.
6. If machining with solid or brazed cemented carbide drills, a rigid set-up and stable working conditions are required.
7. The use of drills with internal cooling channels is recommended.
8. Use a cutting fluid concentration of 15-20 %.

Tapping with HSS

Cutting speed, $v_c = 4-6$ m/min

Remarks:

1. Threading compound or cutting oil gives a longer tool life than emulsion.
2. Fluteless tap (non-cutting) can with advantage be used.